

MINUTE MAN[®]

Power Technologies

From Para Systems, Inc.

Enterprise Plus Series UPS

User's Manual

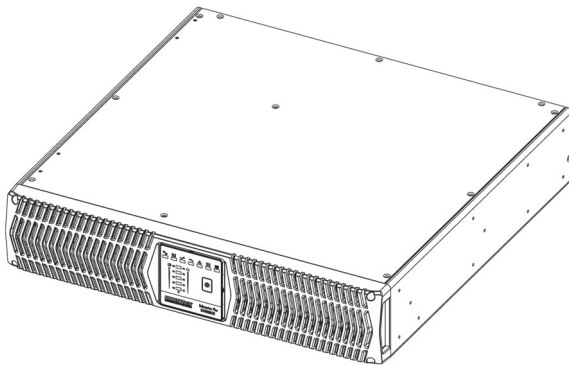

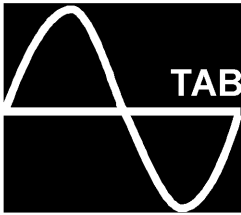

TABLE OF CONTENTS

1.	Introduction	2
2.	Controls and Indicators	6
3.	Installation	9
4.	Operation	15
5.	Troubleshooting	18
6.	Replacing the Battery	19
7.	Obtaining Service	22
8.	Specifications	23
9.	Configurable Parameters & Settings	25
10.	Limited Product Warranty	26
A1.	Declaration of Conformity	28

INTRODUCTION

1

Thank you for purchasing this power protection product. It has been designed and manufactured to provide many years of trouble free service.

IMPORTANT SAFETY INSTRUCTIONS SAVE THESE INSTRUCTIONS !

Please read this manual before installing your Enterprise Plus Series UPS, models E750RM2U, E1000RM2U, E1500RM2U, E1500RMT2U, E2000RM2U, E3000RM2U, E3000RMT2U as it provides important information that should be followed during installation and maintenance of the UPS and batteries allowing you to correctly set up your system for the maximum safety and performance. Included is information on customer support and factory service if it is required. If you experience a problem with the UPS please refer to the Troubleshooting guide in this manual to correct the problem or collect enough information so that the Technical Support Department can rapidly assist you.



This symbol indicates "ATTENTION"



This symbol indicates "Risk of Electrical Shock"



This symbol indicates "Alternating Current Supply Phase"



This symbol indicates "Alternating Current Supply"



This symbol indicates "Direct Current Supply"



This symbol indicates "Equipment Grounding Conductor"



CAUTION! Connect the UPS to a two pole, three wire grounding AC wall outlet. The receptacle must be connected to the appropriate branch protection (circuit breaker or fuse). Connection to any other type of receptacle may result in a shock hazard and violate local electrical codes. Do not use extension cords, adapter plugs, or surge strips.



CAUTION! To reduce the risk of electrical shock with the installation of this UPS equipment and the connected equipment, the user must ensure that the combined sum of the AC leakage current does not exceed 3.5mA.



CAUTION! To reduce the risk of electrical shock in conditions where the load equipment grounding cannot be verified, disconnect the UPS from the AC wall outlet before installing a computer interface cable. Reconnect the power cord only after all signaling connections are made.



WARNING: This Uninterruptible Power Supply contains potentially hazardous voltages. Do not attempt to disassemble the UPS beyond the battery replacement procedure. This UPS contains no user serviceable parts. Repairs and Battery replacement must be performed by **QUALIFIED SERVICE PERSONNEL ONLY.**



WARNING: Risk of Electrical Shock. Hazardous live parts inside these power supplies are energized from the battery even when the AC input is disconnected.



CAUTION! To de-energize the outputs of the UPS:

1. If the UPS is on press and release the On/Off/Test button. **NOTE:** For the 208V models; turn the input circuit breaker to the off position.
2. Disconnect the UPS from the AC wall outlet.
3. To de-energize the UPS completely, disconnect the battery.

NOTICE: This equipment has been tested and found to comply with the limits for a Class B computing device in accordance with the specifications in Subpart J of Part 15 of FCC Rules and the Class B limits for radio noise emissions from digital apparatus set out in the Radio Interference of the Canadian Department of Communications. These limits are designed to provide reasonable protection against such interference in a residential installation. This equipment generates and uses radio frequency and if not installed and used properly, that is, in strict accordance with the manufacturer's instructions, this equipment may cause interference to radio and television reception. If this equipment does cause interference to radio or television reception, which can be determined by turning the equipment off and on, the user is encouraged to try to correct the interference by one or more of the following measures:



- Re-orient the receiving antenna.
- Relocate the computer with respect to the receiver.
- Move the computer away from the receiver.
- Plug the computer into a different outlet so that the computer and receiver are on different branch circuits.
- Shielded communications interface cables must be used with this product.



WARNING: Changes or modifications to this unit not expressly approved by the party responsible for compliance could void the user's authority to operate the equipment.

Receiving Inspection

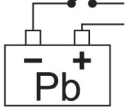
After removing your UPS from its carton, it should be inspected for damage that may have occurred in shipping. Immediately notify the carrier and place of purchase if any damage is found. Warranty claims for damage caused by the carrier will not be honored. The packing materials that your UPS was shipped in are carefully designed to minimize any shipping damage. In the unlikely case that the UPS needs to be returned to the manufacturer, please use the original packing material. Since the manufacturer is not responsible for shipping damage incurred when the system is returned, the original packing material is inexpensive insurance. **PLEASE SAVE THE PACKING MATERIALS!**

 <h3 style="margin: 0;">CAUTION IF DAMAGED</h3>	
 <p>Battery is NOT connected</p>	 <p>BATTERIES, SEALED NON-SPILLABLE Packages, crushed, punctured, or torn such that contents are revealed, should be set aside in an isolated area and be inspected by a qualified person. If the package is deemed to be not shippable, contents shall be promptly collected, segregated, and either the consignor or consignee contacted.</p>

NOTE: These UPSs are shipped with the batteries disconnected. The batteries must be connected before putting these UPSs into service. Refer to Section 3 "Installation" for connecting the batteries.

Life Support Policy

As a general policy, we do not recommend the use of any of our products in life support applications where failure or malfunction of the product can be reasonably expected to cause failure of the life support device or to significantly affect its safety or effectiveness. We do not recommend the use of any of our products in direct patient care. We will not knowingly sell our products for use in such applications unless it receives in writing assurances satisfactory to us that (a) the risks of injury or damage have been minimized, (b) the customer assumes all such risks, and (c) our liability is adequately protected under the circumstances.

Examples of devices considered to be life support devices are neonatal oxygen analyzers, nerve stimulators (whether used for anesthesia, pain relief, or other purposes), auto transfusion devices, blood pumps, defibrillators, arrhythmia detectors and alarms, pacemakers, hemodialysis systems, peritoneal dialysis systems, neonatal ventilator incubators, ventilators for both adults and infants, anesthesia ventilators, and infusion pumps as well as any other devices designated as “critical” by the United States FDA.

Hospital grade wiring devices and leakage current may be ordered as options on many of our UPS systems. We do not claim that units with this modification are certified or listed as Hospital Grade by us or any other organization. Therefore, these units do not meet the requirements for use in direct patient care.

CONTROLS AND INDICATORS

2

CONTROL PANEL

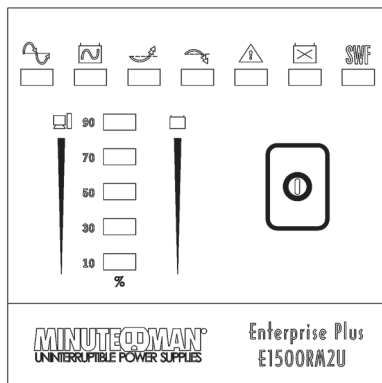

The AC normal (green) LED illuminates in a steady state when the UPS is on and operating in the AC normal mode. The AC normal LED will extinguish when operating in the Battery mode.



The On-Battery (green) LED illuminates in a steady state when the UPS is operating in the Battery mode. The On-Battery LED will extinguish when operating in the AC normal, Boost and Buck modes.



The Boost (yellow) LED illuminates in a blinking state when the UPS is operating in the Boost mode. The Boost LED will extinguish when operating in the AC normal, Buck and Battery modes.



The Buck (yellow) LED illuminates in a blinking state when the UPS is operating in the Buck mode. The Buck LED will extinguish when operating in the AC normal, Boost and Battery modes.



The Fault (red) LED illuminates in a steady state when the UPS detects an internal fault. The Fault LED is extinguished when the UPS is operating properly.



The Weak/Bad Battery (red) LED illuminates in a steady state when the UPS detects a weak battery, bad battery or if the battery is disconnected. The Weak/Bad Battery LED is extinguished when the battery's condition is good.



The Site Wiring Fault (red) LED (120V models) illuminates in a steady state when the UPS detects a site wiring problem. The SWF LED is extinguished when the UPS is connected to proper site wiring.

The Load Level Bar Graph (AC mode only) operates as follows:

LED #10: $\geq 10\%$ load (green/red/yellow) LED will be green and illuminated when there is at least 10% of the rated capacity.

LED #30: $\geq 30\%$ load (green/yellow) LED will be green and illuminated when there is at least 30% of the rated capacity.

LED #50: $\geq 50\%$ load (green/yellow) LED will be green and illuminated when there is at least 50% of the rated capacity.

LED #70: $\geq 70\%$ load (green/yellow) LED will be green and illuminated when there is at least 70% of the rated capacity.

LED #90: $\geq 90\%$ to approximately 109% load (red/yellow) LED will be yellow and illuminated when there is approximately 90% of the rated capacity to indicate that unit is near full capacity. The LED will turn red at 110% load capacity to indicate an Overload condition.



The Battery Capacity Bar Graph (Battery mode only) operates as follows:

LED #90: $\geq 90\%$ battery capacity (red/yellow) LED will be yellow and illuminated until the battery's capacity drops below 80% capacity and then it will extinguish.

LED #70: $\geq 70\%$ battery capacity (green/yellow) LED will be yellow and illuminated until the battery's capacity drops below 60% capacity and then it will extinguish.

LED #50: $\geq 50\%$ battery capacity (green/yellow) LED will be yellow and illuminated until the battery's capacity drops below 40% capacity and then it will extinguish.

LED #30: $\geq 30\%$ battery capacity (green/yellow) LED will be yellow and illuminated until the battery's capacity drops below 30% capacity and then it will extinguish.

LED #10: $\geq 30\%$ battery capacity (green/red/yellow) LED will be yellow and illuminated until the unit issues a Low Battery Warning Alarm and then it will turn red to indicate a Low Battery Warning.



The Multi-Function On/Off/Test Button functions as follows:

When the UPS is Off, press and release the On/Off/Test button after one beep to turn the UPS On. **NOTE:** The input circuit breaker **MUST** be in the on position for the 208V models.

When the UPS is On, press and release the On/Off/Test Button after one beep to turn the UPS Off. **NOTE:** Turn the input circuit breaker to the off position for the 208V models.

When the UPS is On, press and hold the On/Off/Test button for four beeps, then release the button. The UPS will perform a 5-second Self Test.



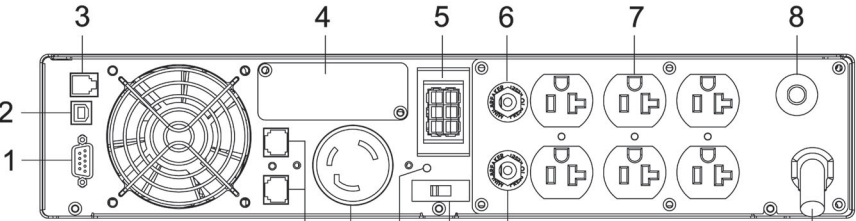

120V Model

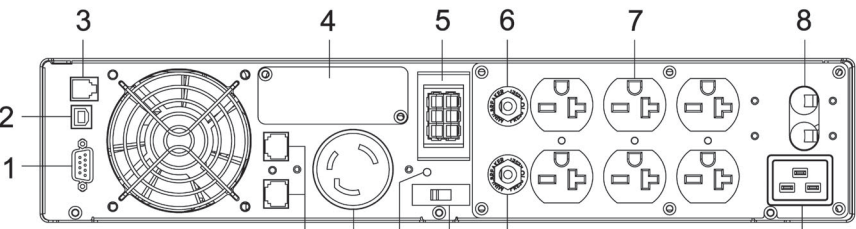

208V Model

1. The RS232 Communications Interface Port is for UPS monitoring and control.
2. The USB Communications Interface Port is for UPS monitoring and control.
3. The RJ11 REPO (Remote Emergency Power Off) Port is for UPS control.
4. The option slot is for option cards.
5. The External Battery Connector is for connecting External Battery Packs.
6. The output circuit breaker will trip in the event the load exceeds the UPS's power rating.
7. The Battery Backup output power receptacles. The output receptacles are electrically wired into two segments to support the "Load Shedding Function". The locking receptacle does not support the Load Shedding Function. **NOTE:** The locking receptacle is not on all models.
8. The input circuit breaker will trip in the event the load exceeds the UPS's power rating.
9. The input power cord (120V models). The AC Power Inlet IEC320 (208V models).
10. The dipswitch is for setting the Inverter (On-Battery) output voltage.
11. The External Ground Stud is for connecting an external ground wire.
12. The R-J11/R-J45 modular connectors are used for 10/100 Base-T Network/single line Phone/Fax/Modem protection.

Model #	Input Power Plug (All power cords are 10ft)	Output Power Receptacles
E750RM2U	NEMA 5-15P	6-NEMA 5-15R
E1000RM2U	NEMA 5-15P	6-NEMA 5-15R
E1500RM2U	NEMA 5-15P	6-NEMA 5-15R
E2000RM2U	NEMA 5-20P	6-NEMA 5-15/20R 1-NEMA L5-20R
E3000RM2U	NEMA L5-30P	6-NEMA 5-15/20R 1-NEMA L5-30R
E1500RMT2U	NEMA 6-15P	6-NEMA 6-15R
E3000RMT2U	NEMA L6-30P	6-NEMA 6-15/20R 1-NEMA L6-30R



3 INSTALLATION

INSTALLATION PLACEMENT

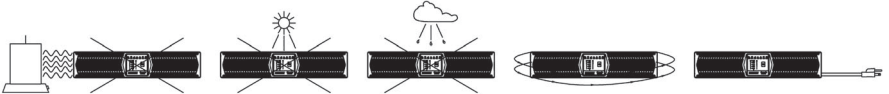

This UPS series is intended to be installed in a temperature controlled environment that is free of conductive contaminants. Select a location which will provide good air circulation for the UPS at all times. Avoid locations near heating devices, water or excessive humidity, or where the UPS is exposed to direct sunlight. Route power cords so they cannot be walked on or damaged.

Operating Temperature (Maximum): 0 to 40 degrees C (+32 to +104 degrees F)

Operating Elevation: 0 to 3,000m (0 to +10,000 ft)

Operating and Storage Relative Humidity: 95%, non-condensing

Storage Temperature: -15 to +45 degrees C (+5 to +113 degrees F)

Storage Elevation: 0 to 15,000m (0 to +50,000 ft)

INSTALLATION

Be sure to read the installation placement and all the cautions before installing the UPS. Place the UPS in the final desired location and complete the rest of the installation procedure. These UPSs are shipped with the internal batteries disconnected. The batteries must be connected before putting these UPSs into service. See the connecting the batteries procedure to connect the batteries and see the Rackmount Configuration to install the UPS into the rack. **USE CAUTION:** The UPS is heavy. Use the appropriate number of personnel when installing the UPS.

CONNECTING THE BATTERIES

(QUALIFIED SERVICE PERSONNEL ONLY)

Please read all of the **WARNINGS** and **CAUTIONS** before attempting to connect the batteries.

1. Remove the UPS from the shipping box and set on the floor or a bench top.
2. Remove the front panel retaining screws.
3. Lay the front panel on top of the UPS.
4. Verify proper polarity. Connect the battery connectors (red and black) together.

NOTE: Some sparking might occur, this is normal.

5. Re-install the front panel onto the UPS.
6. Re-install the front panel retaining screws.
7. Continue with the rest of the Installation.

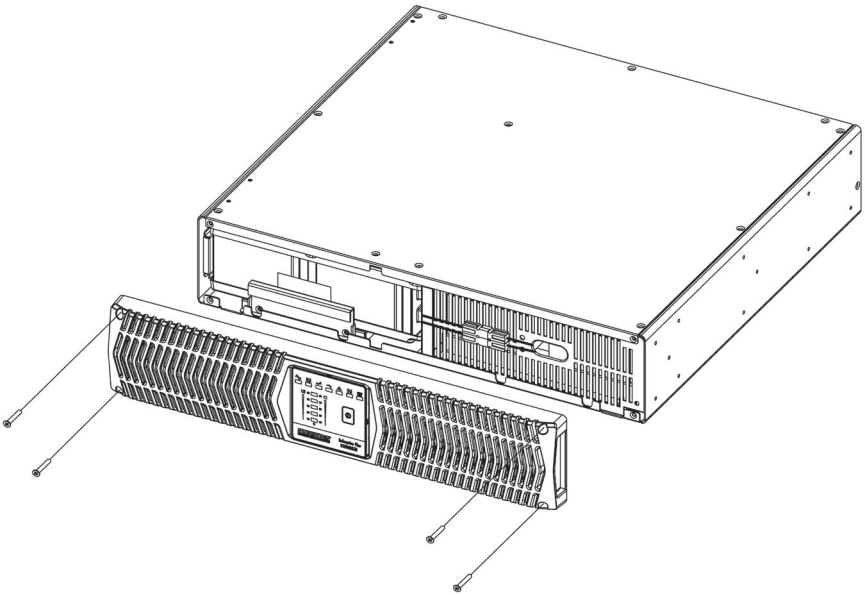

RACKMOUNT CONFIGURATION

This UPS comes with mounting brackets for the standard 19" (46.5cm) rack. The mounting brackets to fit a 23" (59.2cm) standard rack are also available. The screws for mounting the UPS to the rack are not included (screw size varies with rack size).

1. Locate the mounting bracket screw holes on the side panels of the UPS, at the front of the UPS. **NOTE:** The mounting brackets can also be mounted in the middle of the UPS.
2. Align the mounting bracket with the mounting bracket screw holes.
3. Attach the mounting bracket with the retaining screws.
4. Mount the UPS into the rack and secure with the retaining screws. **WARNING:** Use two or more people when installing the UPS. Use **CAUTION**, the UPS is extremely heavy. Do not move the rack after the units have been installed. The rack maybe unstable due to the weight distribution.
5. The Rackmount Configuration is complete. See Connecting your Equipment.

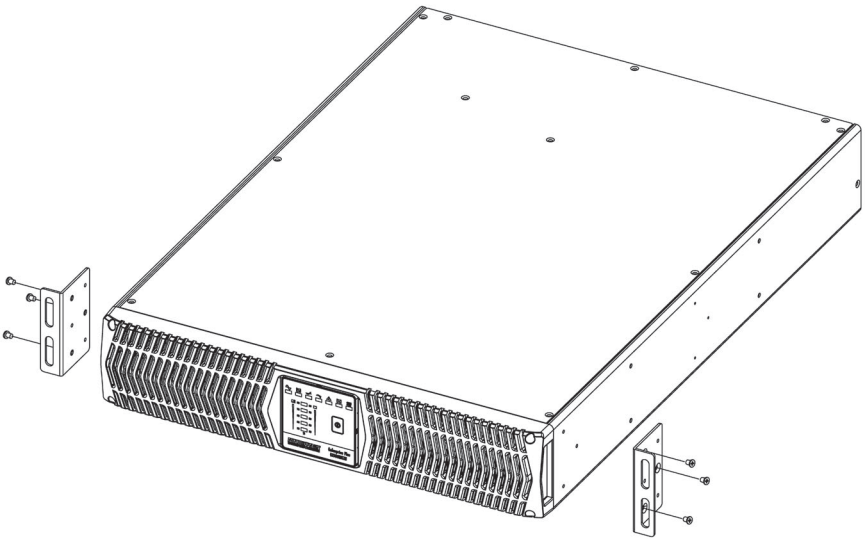

TOWER CONFIGURATION

The tower configuration allows the user to install the UPS in the up-right position next to the tower computer. The tower brackets are provided with the UPS. **WARNING:** Use two or more people when installing the UPS. Use **CAUTION**, the UPS is extremely heavy.

1. Once the location of the UPS has been determined, place the tower brackets in the desired location.

WARNING: The UPS must be installed in the proper up-right position. If the UPS is not installed in the proper up-right position the Batteries will be damaged. Once the UPS is placed in the tower brackets, looking at the front panel the **YELLOW** Battery disconnected label on the top cover of the UPS **MUST** be on your left hand side.

2. Slide the UPS into the tower brackets. Make sure that the UPS is stable.

3. The LED face plate can be rotated to read in the up-right position. Remove the front panel from the UPS. On the backside of the front panel, push the LED face plate outwards the face plate will pop out. Position the LED face plate so that it reads in the up-right position. Re-install the front panel on the UPS.

4. The Tower Configuration is complete. See Connecting your Equipment.

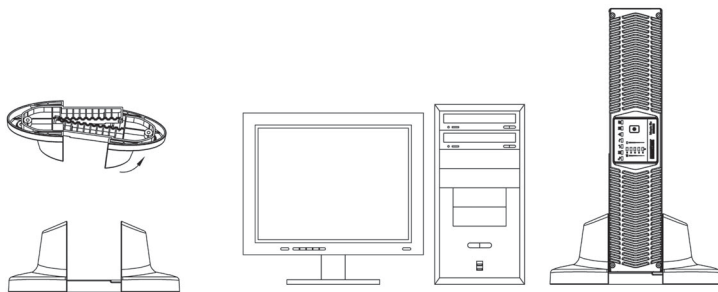

DESKTOP CONFIGURATION

The desktop configuration allows the user to install the monitor, the computer and the UPS in one single stack. **WARNING:** Use two or more people when installing the UPS. Use **CAUTION**, the UPS is extremely heavy.

1. Once the location of the UPS has been determined, lay the UPS down flat on the desk.

2. Stack the computer and then the monitor on top of the UPS. **NOTE:** Do not stack the UPS on top of the computer. The UPS is heavy and may damage the other equipment.

3. The Desktop Configuration is complete. See Connecting your Equipment.

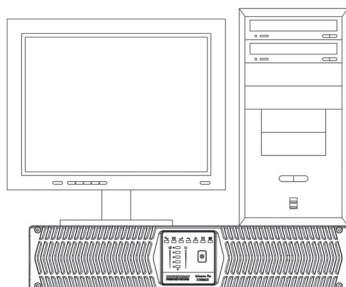

WALLMOUNT CONFIGURATION

The wallmount configuration allows the user to mount the UPS on the wall. There is a wallmount bracket kit available for the UPS. The kit includes two wall mounting brackets, ten retaining screws, and the wallmount template. **WARNING:** Use two or more people when installing the UPS. Use **CAUTION**, the UPS is extremely heavy. The UPS's side panels have mounting bracket screw holes for attaching the wall mounting brackets.

1. Once the location and position of the UPS has been determined, lay the UPS down flat.

WARNING: The UPS must be installed in the proper up-right position. If the UPS is not installed in the proper up-right position the Batteries will be damaged. Once the UPS is placed on the wall, looking at the front panel the **YELLOW** Battery disconnected label on the top cover of the UPS **MUST** be on your left hand side.

2. Align the mounting brackets with the mounting bracket screw holes and attach with the six retaining screws.
3. Use the template to mark the screw hole position on the wall. **CAUTION**, you should always wear protective gear for your hands and eyes when operating power tools.
4. Attach the four retaining screws to the wall and make sure that all of the retaining screws are screwed into structural material. Then clean the area of any loose material. Do not tighten the retaining screws all the way, leave approximately 3/8" of the retaining screws sticking out.
5. Position the UPS, so that the mounting bracket keyed holes line up with the four retaining screws. Slide the UPS down until its resting securely on the four retaining screws.
6. Tighten the four retaining screws to secure the UPS to the wall.
7. The LED face plate can be rotated to read in the up-right position. Remove the front panel from the UPS. On the backside of the front panel, push the LED face plate outwards the face plate will pop out. Position the LED face plate so that it reads in the up-right position. Re-install the front panel on the UPS.
8. The Wallmount Configuration is complete. See Connecting your Equipment.

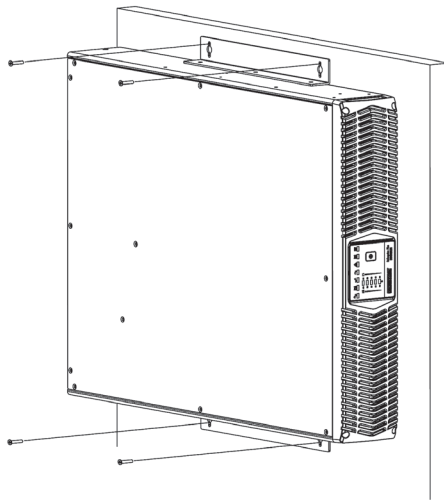

CONNECTING YOUR EQUIPMENT

Plug the equipment into the output receptacles on the rear panel of the UPS. Do not use extension cords, adapter plugs or surge strips on the output of the UPS. Ensure that you do not exceed the maximum output rating of the UPS (refer to the information label or the Electrical Specifications in this manual).

CAUTION! **DO NOT** connect a laser printer to the output receptacles on the UPS, unless the UPS is rated 2000VA or greater. A laser printer draws significantly more power when printing than at idle and may overload the UPS.



CONNECTING THE UPS TO AN AC SOURCE

Plug the UPS into a two pole, three wire, grounded receptacle only. Do not use extension cords, adapter plugs, or surge strips.

CHECKING THE SITE WIRING FAULT (120V Models)

After plugging in the UPS, check the Site Wiring Fault (SWF) LED on the front panel of the UPS. If the SWF LED is illuminated, the UPS is plugged into an improperly wired AC outlet. If the UPS indicates a Site Wiring Fault (SWF), have a Qualified Electrician correct the problem.

CHARGING THE BATTERY

The UPS will charge the internal batteries whenever the UPS is connected to an AC source and there is an acceptable AC voltage present. **NOTE:** The input circuit breaker **MUST** be in the on position for the 208V models. It is recommended that the UPS's batteries be charged for a minimum of 4 hours before use. The UPS may be used immediately, however, the "On-Battery" runtime may be less than normally expected. **NOTE:** If the UPS is going to be out of service or stored for a prolonged period of time, the batteries must be recharged for at least twenty-four hours every ninety days.

COMMUNICATIONS PORT CONNECTION (OPTIONAL)

The Power Monitoring Software and interface cables can be used with the UPS. Use only the interface cables that come with these UPSs. Connect the interface cable (Serial or USB) to the appropriate communications port on the rear panel of the UPS. Connect the other end of the cable to the device that will be monitoring/controlling the UPS. **NOTE:** Connecting to the Communications Port is optional. The UPS works properly without this connection.

NETWORK/PHONE/FAX/MODEM PROTECTION CONNECTION (OPTIONAL)

Connect a 10/100 Base-T network, single line phone, Fax or Modem line to the RJ11/45 modular connectors on the rear panel of the UPS. This connection will require another length of telephone or network cable. The cable coming from the telephone service or networked system is connected to the port marked "IN". The equipment to be protected is connected to the port marked "OUT". **NOTE:** Connecting to the Network/Phone/Fax/Modem modular connectors is optional. The UPS works properly without this connection.

RJ11 REPO (Remote Emergency Power Off) PORT (OPTIONAL)

Connect one end of the RJ11 cable to the REPO port and the other end of the RJ11 cable to the EPO switch. In the AC or the Battery mode short pin4 to pin5 for approximately 0.5-seconds to shutdown the UPS. The UPS must be turned off and then back on again to restart the UPS. **NOTE:** Connecting to the REPO port is optional. The UPS works properly without this connection.



4 OPERATION

SYSTEM OVERVIEW

This Line-Interactive UPS protects computers, internetworking, and telecommunications equipment from blackouts, brownouts, overvoltages, and surges. The AVR function continuously corrects the voltages, in-between the brownout and overvoltage transfer points (80 - 164VAC/150 - 271VAC), to a safe usable level. When the UPS is operating in the AVR mode the audible alarm will remain silent and the Boost or the Buck indicator will blink. During normal AC operation, the UPS will quietly and confidently protect your system from power anomalies.

The UPS will charge the batteries with the UPS in the on or off position as long as the UPS is plugged into the wall outlet and there is an acceptable AC voltage present (80 - 164VAC/150 - 271VAC). **NOTE:** The input circuit breaker **MUST** be in the on position for the 208V models. When a blackout, brownout, or an overvoltage condition occurs; the UPS will transfer to the battery mode, the On-Battery indicator will illuminate and the audible alarm will sound once every ten-seconds indicating that the commercial power is lost or unacceptable. When the commercial power returns or is at an acceptable level, the UPS will automatically transfer back to the AC normal mode and start recharging the batteries. During an extended outage when there is approximately two-minutes of backup time remaining the audible alarm will sound twice every five-seconds. This Low Battery Warning is letting the user know that they should save all open files and turn off their computer. When the batteries reach the predetermined level the UPS will automatically shutdown protecting the batteries from over discharging. Once the commercial power returns the UPS will automatically restart, providing safe usable power to the connected equipment and start recharging the batteries.

TURNING THE UNIT ON/OFF

On / Off / Test Button



Press and release the On/Off/Test Button after one beep to turn the UPS on and supply power to the load. **NOTE:** The input circuit breaker **MUST** be in the on position for the 208V models to turn the UPS on. The load is immediately powered while the UPS runs a five-second self test. Press and release the On/Off/Test Button after one beep to turn the UPS off. **NOTE:** Turn the input circuit breaker to the off position for the 208V models. The UPS will continue to charge the batteries whenever it is plugged into a wall outlet and there is acceptable AC voltage present.

SELF TEST

The self test feature is useful to verify the correct operation of the UPS and the condition of the batteries. With the UPS in the AC normal mode, press and hold the On/Off/Test Button for four beeps, then release the button. The UPS will perform a ten-second self test. During the self test, the UPS will switch to battery power and the On-Battery LED will illuminate and the audible alarm will sound. The length of the test that is automatically performed every two weeks is longer than the start-up or user invoked test. This test will run for approximately fifteen-seconds to measure the battery's capability to provide an acceptable amount of runtime. If the UPS fails a self test, one of the LEDs will remain illuminated indicating the type of problem. **NOTE:** The UPS will automatically perform a self test on start-up and every two weeks.

DIPSWITCH SETTINGS

The dipswitch setting may be changed by the user to set the desired Inverter (On-Battery) output voltage. The dipswitch must be set to the desired Inverter (On-Battery) output voltage and then the UPS must be turned off and restarted to reconfigure the microprocessor and save the changes. The Inverter (On-Battery) output voltage setting can be either 120VAC (208VAC) default or 127VAC (240VAC). Changing the Inverter (On-Battery) output voltage to 127VAC, will also change the Buck setpoint. Changing the Inverter (On-Battery) output voltage to 240VAC, will also change the Brownout, Boost, Buck and Overvoltage setpoints.

LOAD SHEDDING FUNCTION

The output receptacles are electrically wired into two segments to support the "Load Shedding Function". The user can control the two segments individually or both at the same time. The Load Shedding Function is controllable by the Power Monitoring Software or the SNMP card.

COMMUNICATIONS PORTS (RS232 and USB)

The RS232 communication port is a standard DB9 female with both RS232 and simulated contact closure capability. The UPS will poll the port and activate the port for RS232 or contact closure in accordance with the type of cable it finds connected to the port. To change the port configuration requires the unit be turned off and restarted with the desired cable connected. The pinout for the port is depicted per the chart below:

Pin 1: Simulated contact closure Low Battery Warning, NO

Pin 2: /TXD

Pin 3: /RXD and receive UPS shutdown command (connect to pin 9 for 4-seconds. The shutdown command is only active in the battery mode)

Pin 4: Not Used

Pin 5: Ground

Pin 6: Not Used

Pin 7: Not Used

Pin 8: Simulated contact closure AC fail, NO

Pin 9: Atx Signal (high level: +12V +/-2V, low level: -15V +/- -2V)

USB PORT

The USB protocol is HID. The HID USB driver is standard in the Windows OS. Simply plug the USB cable into the UPS and the computer then follow the prompts on the screen.

RJ11 REPO (Remote Emergency Power Off) PORT

Connect one end of the RJ11 cable to the REPO port and the other end of the RJ11 cable to the EPO switch. In the AC or the Battery mode short pin4 to pin5 for approximately 0.5-seconds to shutdown the UPS. The UPS must be turned off and then back on again to restart the UPS.

POWER MONITORING SOFTWARE

The UPS comes with a Power Monitoring Software CD. See the software CD for the installation of the Power Monitoring Software.

OPTION SLOT

The option slot on the rear panel of the UPS is for option cards. Contact your local dealer for the available option cards.

ALARMS

ON BATTERY

When the UPS is operating on the batteries, the On-Battery LED will illuminate and the audible alarm will sound once every ten-seconds. The alarm will stop once the UPS returns to the AC normal mode.

LOW BATTERY WARNING

The UPS will sound two beeps every five-seconds when the battery reserve runs low. This condition will continue until AC returns or the UPS shuts down from battery exhaustion.

WEAK/BAD BATTERY

The UPS automatically tests the battery's condition and will illuminate the Weak/Bad Battery LED and sound the alarm. This alarm will be repeated until the batteries pass a self test. If the battery is weak, bad or disconnected, the Weak/Bad Battery LED will illuminate and the alarm will beep three times every five-minutes until the battery is reconnected or replaced. It is recommended that the UPS be allowed to charge overnight before performing a battery test to confirm a Weak/Bad Battery condition.

NOTE: If the UPS has a Weak/Bad Battery Alarm after reconnecting or replacing the batteries, the user must initiate a self test to clear the Weak/Bad Battery Alarm. To initiate a self test see section 4 "**SELF TEST**".

OVERLOAD

When the amount of load attached to the UPS exceeds its power rating, the Overload LED will illuminate (AC mode only) and the UPS will sound a constant alarm (AC and Battery modes). This alarm will remain on until the excess load is removed or the UPS's self protection circuit shuts the UPS down. If the UPS shuts down because of an Overload condition in the battery mode, the UPS must perform an Inverter function or a Self Test to clear the Overload Alarm.

UPS FAULT

When the UPS detects a hardware fault, the Fault LED will illuminate and the UPS will sound a constant alarm. The fault condition, in some instances, may be reset by turning the UPS off and then on.

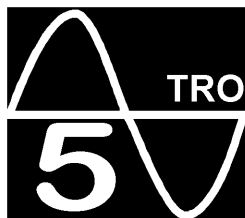

TROUBLESHOOTING

Symptom	Possible Cause	What To Do
UPS will not turn on	On/Off/Test button not pushed	Press and release the On/Off/Test button to start UPS
UPS operates in battery mode only, even though there is normal AC present	Input AC circuit breaker is tripped	Reset circuit breaker by pressing the plunger back in. If the AC circuit breaker trips after UPS starts up, reduce the load on the UPS
Fault LED is illuminated	UPS has detected an internal fault	Call for service
Site Wiring Fault LED is illuminated	Incorrect service wiring	Have a Qualified Electrician correct the service wiring
The AC normal LED is illuminated, but there is no output	The UPS is being controlled via its communications port	Disconnect the computer cable from the UPS and press the On button. If UPS works normally, the software has control of the UPS
UPS does not provide expected runtime	The batteries may be weak or at the end of useful service life	Charge the batteries for 8-hours and retest. If the runtime is still less than expected, the batteries may need to be replaced, even though the Weak/Bad Battery LED is not illuminated
Weak/Bad Battery LED is illuminated	Loose connections at the batteries, Weak batteries, Bad batteries	Check battery connections, charge the batteries for 8-hours, replace the batteries
UPS occasionally emits a beep	Normal operation	The UPS is performing its intended function
Overload LED is illuminated and a constant alarm	The load has exceeded the UPS's capacity	Check the specifications (see section 8). Remove part of the load
The Boost LED or Buck LED is blinking.	The UPS is in either the Boost mode or the Buck mode	The UPS is performing its intended function

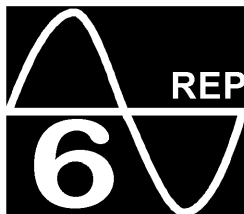

REPLACING THE BATTERY

REPLACING THE BATTERY

(QUALIFIED SERVICE PERSONNEL ONLY)

This UPS has an easy to replace hot-swappable batteries. Please read all of the **WARNINGS** and **CAUTIONS** before attempting to service the batteries. **NOTE:** If there is a power interruption while replacing the hot-swappable batteries, with the UPS on, the load will not be backed up.

WARNING! This Uninterruptible Power Supply contains potentially hazardous voltages. Do not attempt to disassemble the UPS beyond the battery replacement procedure. This UPS contains no user serviceable parts. Repairs and Battery replacement must be performed by **QUALIFIED SERVICE PERSONNEL ONLY**.



CAUTION: Do not open or mutilate batteries. Released electrolyte is harmful to the skin and eyes and may be toxic.

CAUTION: Do not dispose of batteries in a fire. The batteries may explode. The batteries in this UPS are recyclable. Dispose of the batteries properly. The batteries contain lead and pose a hazard to the environment and human health if not disposed of properly. Refer to local codes for proper disposal requirements or return the battery to the supplier.



CAUTION: Although battery system voltages are only 36VDC and 72VDC the battery system can still present a risk of electrical shock. These batteries produce sufficient current to burn wire or tools very rapidly, producing molten metal. Observe these precautions when replacing the batteries:



1. Remove watches, rings, or other metal objects.
2. Use hand tools with insulated handles.
3. Wear protective eye gear (goggles), rubber gloves and boots.
4. Do not lay tools or other metal parts on top of batteries.
5. Disconnect the charging source prior to connecting or disconnecting the battery terminals.
6. Determine if the battery is inadvertently grounded. If the battery is, remove the source of the grounding. Contact with any part of a grounded battery can result in an electrical shock. The likelihood of such shock will be reduced, if such grounds are removed during installation and maintenance.

CAUTION: Replace batteries with the same number and type as originally installed in the UPS. These batteries have pressure operated vents. These UPSs contain sealed non-spillable maintenance-free lead acid batteries.

Model #	E750RM2U E1000RM2U	E1500RM2U E1500RMT2U	E2000RM2U	E3000RM2U E3000RMT2U
Battery Qty/Rating	3-12V7.2Ah	3-12V8.5Ah	6-12V7.2Ah	6-12V8.5Ah
CSB Part #	GP 1272 F2	HR 1234W F2	GP 1272 F2	HR 1234W F2
Panasonic Part #	LC-R127.2	LC-R129	LC-R127.2	LC-R129
Yuasa Part #	NP-7.2-12	REW45-12	NP-7.2-12	REW45-12

BATTERY REPLACEMENT PROCEDURE

PLEASE READ THE CAUTIONS AND WARNINGS BEFORE ATTEMPTING TO REPLACE THE BATTERIES

Hot-swappable batteries mean that the batteries can be replaced without powering down the whole UPS system.

NOTE: If there is a power interruption while replacing the hot-swappable batteries, with the UPS on, the load will not be backed up. To hot-swap the batteries start with step number 6.

1. Turn off the equipment that is plugged into the output receptacles of the UPS.
2. Press and release the On/Off/Test button on the front panel to turn the UPS OFF. **NOTE:** Turn the input circuit breaker to the off position for the 208V models.
3. Unplug the UPS's AC power cord from the AC wall outlet.
4. Unplug the equipment from the output receptacles of the UPS.
5. Unplug the computer interface cable from the rear panel of the UPS.
6. Remove the front panel retaining screws. (FIG. 2)
7. Lay the front panel on top of the UPS.

FIG. 1

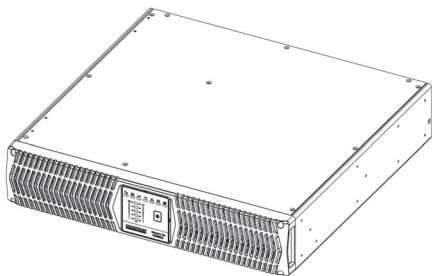
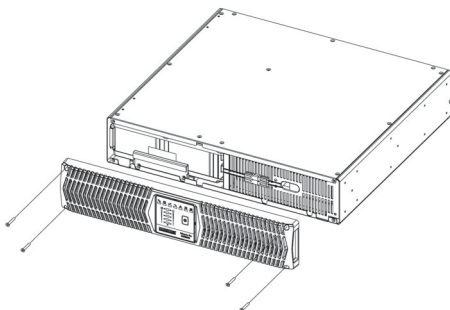

FIG. 2



8. Remove the two retaining screws for the battery retaining bracket. (FIG. 3)
9. Remove the battery retaining bracket. (FIG. 3)
10. Disconnect the Battery connectors (red and black). (FIG. 4)
11. Grasp the battery pull tab and gently pull the battery module out of the UPS and set on the floor. (FIG. 4)

NOTE: Use Caution, the battery module is heavy.

12. Disconnect the battery positive (red) wire.
13. Disconnect the battery negative (black) wire.
14. Remove the battery jumper wires.
15. Remove the old batteries from the battery module.
16. Install the new batteries into the battery module in the same position as the original batteries.
17. Verify proper polarity. Re-install the battery jumper wires on the new batteries.
18. Verify proper polarity. Reconnect the battery negative (black) wire.
19. Verify proper polarity. Reconnect the battery positive (red) wire.
20. Slide the battery module into the UPS.
21. Verify proper polarity. Reconnect the battery connectors (red and black).

NOTE: Some sparking might occur, this is normal.

22. Re-install the battery retaining bracket.
23. Re-install the two retaining screws for the battery retaining bracket.
24. Re-install the front panel on the UPS.
25. Re-install the front panel retaining screws.
26. Properly dispose of the old batteries at an appropriate recycling facility or return them to the supplier in the packing material for the new batteries.
27. The UPS is now ready for the normal operation.

NOTE: If the UPS has a Weak/Bad Battery Alarm after replacing the batteries, the user must initiate a self test to clear the Weak/Bad Battery Alarm. To initiate a self test see section 4 "**SELF TEST**".

FIG. 3

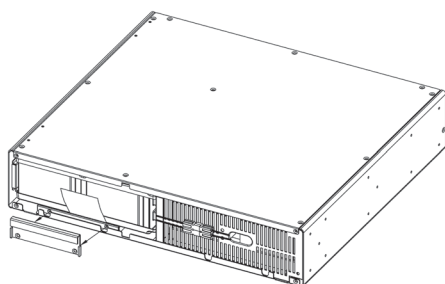
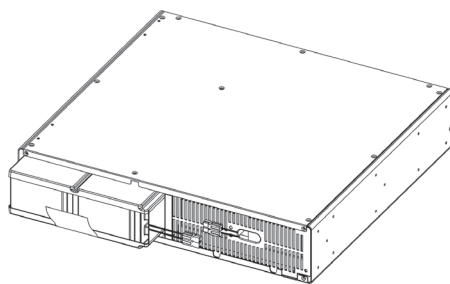

FIG. 4





OBTAINING SERVICE

English

IF THE UPS REQUIRES SERVICE

1. Use the **TROUBLESHOOTING** section to eliminate obvious causes.
2. Verify there are no circuit breakers tripped. A tripped circuit breaker is the most common problem.
3. Call your dealer for assistance. If you cannot reach your dealer, or if they cannot resolve the problem call or fax the Technical Support department at the following numbers; Voice phone (972) 446-7363, FAX line (972) 446-9011 or visit our Web site at www.minutemanups.com the "Discussion Board". Please have the following information available **BEFORE** calling the Technical Support Department.
 - A. Your name and address.
 - B. Where and when the unit was purchased.
 - C. All of the model information about your UPS.
 - D. Any information on the failure, including LEDs that may be illuminated.
 - E. A description of the protected equipment, including model numbers if possible.
 - F. A technician will ask you for the above information and, if possible, help solve your problem over the phone. In the event that the unit requires factory service, the technician will issue you a Return Material Authorization Number (RMA #).
 - G. If the UPS is under warranty, the repairs will be done at no charge. If not, there will be a charge for repair.
4. Pack the UPS in its original packaging. If the original packaging is no longer available, ask the Technical Support Technician about obtaining a new set. It is important to pack the UPS properly in order to avoid damage in transit. Never use Styrofoam beads for a packing material.
 - A. Include a letter with your name, address, day time phone number, RMA number, a copy of your original sales receipt, and a brief description of the problem.
5. Mark the RMA # on the outside of all packages. The factory cannot accept any package without the RMA # marked on the outside.
6. Return the UPS by insured, prepaid carrier to:

Para Systems Inc.
MINUTEMAN UPS
1455 LeMay Drive
Carrollton, TX 75007
ATTN: RMA # _____

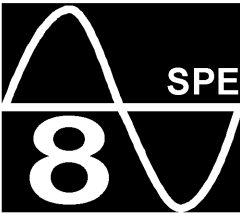

SPECIFICATIONS

SYSTEM SPECIFICATIONS					
Model Number	E750RM2U	E1000RM2U	E1500RM2U E1500RMT2U	E2000RM2U	E3000RM2U E3000RMT2U
Topology	Line-Interactive, Sine Wave				
Maximum Power Capacity	750VA 600W	1000VA 800W	1500VA 1200W	2000VA 1760W	3000VA 2560W
INPUT					
Number of Phase	Single (1Ø 2W +G)				
Nominal Voltage	120VAC (208VAC)				
Acceptable Input voltage	0 - 165VAC (0 - 300VAC)				
Voltage Range	80 - 164VAC (150 - 271VAC)				
Frequency Limits	50 or 60 Hz, +/-6Hz, autosensing				
Low Voltage Transfer Point	80V (150V) resets to Utility Power at 85V (157V) or higher				
High Voltage Transfer Point	164V (271V) resets to Utility Power at 159V (264V) or lower				
Input Protection	Resettable Circuit Breaker				
OUTPUT NON-BATTERY OPERATION					
Voltage Range	120VAC: 105 - 134VAC (208VAC: 189 - 236VAC)				
Voltage Regulation	120VAC: -12.5% - +11.7% (208VAC: -9.1% - +13.5%)				
Frequency Range	60Hz: 54 - 66Hz or 50Hz: 44 - 56Hz				
Efficiency (Line Mode)	>93% (Full Load)				
OUTPUT BATTERY OPERATION					
Waveform Type	Sine Wave				
Nominal Voltage	Default: 120VAC (208VAC), User selectable: 127VAC (240VAC)				
Voltage Regulation	Nominal +/-5% (until Low Battery Warning)				
Frequency	50/60Hz, +/-0.1Hz (unless synchronized to utility)				
Voltage T.H.D.	<5% (Linear Load)				
Dynamic Response	+/-10% @ 100% Load change in 30 ms				
Transfer Time	2-6 ms Typical				
Slew Rate	≤1Hz / second				
Overload Capacity	110% for 20-seconds 125% for 10-seconds 150% Shutdown Immediately				
Protection	Over-Current, Short-Circuit Protected and Latching Shutdown				

BATTERY SYSTEM

Battery Type	Sealed, Non-Spillable, Maintenance Free, Value Regulated Lead Acid				
Typical Recharge Time	8-hours from total discharge				
Typical Battery Life	3-5 years, depending on discharge cycles and ambient temp				
System Voltage	36VDC	36VDC	36VDC	72VDC	72VDC
Battery: Quantity/Rating	3-12V7.2Ah	3-12V7.2Ah	3-12V8.5Ah	6-12V7.2Ah	6-12V8.5Ah
Runtime: Half Load (minutes)	17	15	11	13	8
Runtime: Full Load (minutes)	8	5	4	5	3

SURGE PROTECTION AND FILTERING

Surge Energy Rating	800 J (600 J)				
Surge Current Capability	6500 Amps total				
Surge Response Time	0 ns (instantaneous) normal mode; <5 ns common mode				
Surge voltage let-through (as a percentage of an applied ANSI C62.41 Cat. A +/-6 kV)	<5%				
10/100 Base-T surge protection let-through (as a percentage of an applied +/-6 kV 1.2/50 us, 500 a 8/20 uS test)	<5%				
Telephone line surge protection let-through (as a percentage of an applied +/-6 kV 1.2/50 us, 500a 8/20 uS test)	<1%				
Noise Filter	normal and common mode EMI/RFI suppression				
Audible Noise at 1 m (3 ft.)	<45 dBA			<60 dBA	

ENVIRONMENTAL

Operating Temperature (max)	0 to 40°C (+32 to +104°F)				
Storage Temperature	-15 to +45°C (+5 to +113°F)				
Operating/Storage Humidity	95% Non-Condensing				
Operating Elevation	0 to 3,000m (0 to +10,000 ft)				
Storage Elevation	0 to 15,000m (0 to +50,000 ft)				

PHYSICAL

Size - Net D X W X H	17.0 x 17.3 x 3.5" 432 x 440 x 89 mm	24.0 x 17.3 x 3.5" 610 x 440 x 89 mm
Weight - Net	46.2 lbs 21.0 Kgs	110.9 lbs 50.4 Kgs
Size - Shipping D X W X H	23.6 x 20.0 x 9.0" 600 x 508 x 230 mm	39.4 x 23.6 x 9.0" 1000 x 600 x 230 mm
Weight - Shipping	55.0 lbs 25.0 Kgs	127.0 lbs 57.3 Kgs

REGULATORY COMPLIANCE

Safety and Approvals	UL1778, cUL (CSA 22.2 no. 107.1)
EMC Verification	FCC Class B, CE certified

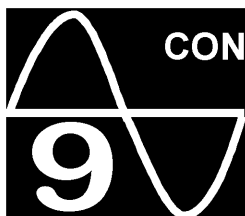

CONFIGURABLE PARAMETERS AND SETTINGS

(These items may require optional software or hardware)

Function	Factory Default	User Choices	Description
UPS ID	Enterprise Plus Series	Up to 64 characters to define the UPS	Use this function to uniquely identify the UPS in your network configuration
Battery install date	Date of manufacture	Date of battery replacement - month/day/year XXXXXX	Enter the current date when replacing batteries
Battery life in days	1826	Up to 5 characters	At first battery replacement, reset to reflect actual number of days experience in your environment or leave factory default
Enable/Disable auto restart	Enabled	Enable or Disable	When <u>enabled</u> , the UPS will automatically restart from a low battery shutdown when normal AC returns
Set audible alarm state	Enabled	Enabled, at low battery, disabled	<u>Enabled</u> - the UPS will emit a short beep when in the battery mode. <u>At Low Battery</u> the UPS will emit two beeps from low battery warning until shutdown. <u>Disabled</u> - Use only when software is controlling the UPS or to silence the alarm
Shut-down Type	Entire UPS	Entire UPS or UPS output	<u>Entire UPS</u> - Turns off the entire UPS. <u>UPS Output</u> - Turns off the UPS's output receptacles only.
Set inverter output voltage	120VAC (208VAC)	120, 127VAC (208, 240VAC)	Changes output voltage for battery mode operation
Enable/Disable REPO	Disabled	Enable or Disable	<u>Enabled</u> - the UPS will be powered off and remain off until the UPS is reset



LIMITED PRODUCT WARRANTY

Para Systems Inc. (Para Systems) warrants this equipment, when properly applied and operated within specified conditions, against faulty materials or workmanship for a period of three years from the date of purchase. For equipment sites within the United States and Canada, this warranty covers repair or replacement of defective equipment at the discretion of Para Systems. Repair will be from the nearest authorized service center. Replacement parts and warranty labor will be borne by Para Systems. For equipment located outside of the United States and Canada, Para Systems only covers faulty parts. Para Systems products repaired or replaced pursuant to this warranty shall be warranted for the unexpired portion of the warranty applying to the original product. This warranty applies only to the original purchaser who must have properly registered the product within 10 days of purchase.

The warranty shall be void if (a) the equipment is damaged by the customer, is improperly used, is subjected to an adverse operating environment, or is operated outside the limits of its electrical specifications; (b) the equipment is repaired or modified by anyone other than Para Systems or Para Systems approved personnel; or (c) has been used in a manner contrary to the product's User's Manual or other written instructions.

Any technical advice furnished before or after delivery in regard to use or application of Para Systems's equipment is furnished without charge and on the basis that it represents Para Systems's best judgment under the circumstances, but it is used at the recipient's sole risk.

EXCEPT AS PROVIDED HEREIN, PARA SYSTEMS MAKES NO WARRANTIES, EXPRESSED OR IMPLIED, INCLUDING WARRANTIES OF MERCHANTABILITY AND FITNESS FOR A PARTICULAR PURPOSE. Some states do not permit limitation of implied warranties; therefore, the aforesaid limitation(s) may not apply to the purchaser.

LIMITED PRODUCT WARRANTY

(Continued)

EXCEPT AS PROVIDED ABOVE, IN NO EVENT WILL PARA SYSTEMS BE LIABLE FOR DIRECT, INDIRECT, SPECIAL, INCIDENTAL, OR CONSEQUENTIAL DAMAGES ARISING OUT OF THE USE OF THIS PRODUCT, EVEN IF ADVISED OF THE POSSIBILITY OF SUCH DAMAGE. Specifically, Para Systems is not liable for any costs, such as lost profits or revenue, loss of equipment, loss of use of equipment, loss of software, loss of data, cost of substitutes, claims by third parties, or otherwise. The sole and exclusive remedy for breach of any warranty, expressed or implied, concerning Para Systems's products and the only obligation of Para Systems hereunder, shall be the repair or replacement of defective equipment, components, or parts; or, at Para Systems's option, refund of the purchase price or substitution with an equivalent replacement product. This warranty gives you specific legal rights and you may also have other rights which vary from state to state.

Longer term warranties are available at an additional cost. Contact Para Systems (1-972-446-7363) for details.

A1. DECLARATION OF CONFORMITY

Application of Council Directive(s): 89/336/EEC, 73/23/EEC

Standard(s) to which Conformity is declared: EN55022, EN55024
EN61000-6-1, EN61000-6-3
EN61000-4-5

Manufacturer's Name: Para Systems, Inc. (MINUTEMAN UPS)

Manufacturer's Address: 1455 LeMay Drive
Carrollton, Texas 75007 USA

Type of Equipment: Uninterruptible Power Supplies (UPS)
Model No: E750RM2U (Y), E1000RM2U (Y), E1500RM2U (Y),
E2000RM2U (Y), E3000RM2U (Y)

Year of Manufacture: Beginning August 1, 2006

I hereby declare that the equipment specified above conforms to the above Directive(s).

Robert Calhoun
(Name)

Manager Engineering
(Position)

Place: Carrollton, Texas, USA

Date: August 1, 2006

Notes:



Notes:



This product complies with the Restriction of certain Hazardous Substances (RoHS) Directive as conceived by the European Union committee in 2002. Products that meet the RoHS standard have been redesigned to remove the lead, mercury, cadmium, hexavalent chromium where applicable. As part of our efforts to maintain a healthy environment, Para Systems has proactively adopted these standards for our Minuteman® brand products.

Para Systems, Inc.
1455 Lemay Dr.
Carrollton, TX 75007
Phone: 1-972-446-7363
Fax: 1-972-446-9011
Internet: minutemanups.com
UPS Sizing: sizemyups.com

PN - 34000271