

MINUTE MAN[®] **Power Technologies** *From Para Systems, Inc.*

Enterprise Plus Battery Packs

User's Manual

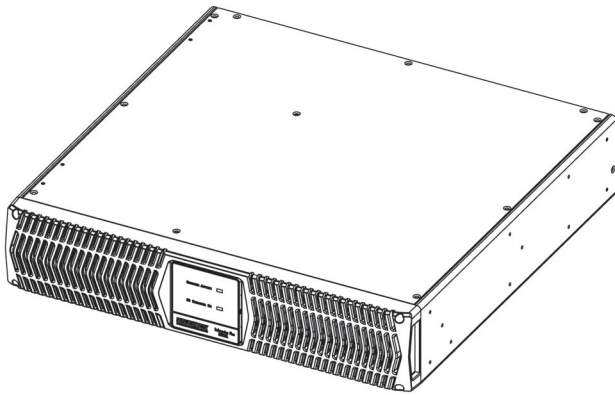

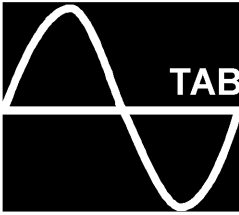
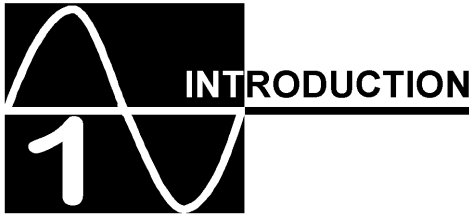

TABLE OF CONTENTS

1.	Introduction	2
2.	Controls and Indicators	6
3.	Installation	7
4.	Operation	14
5.	Troubleshooting	15
6.	Replacing the Battery	16
7.	Obtaining Service	20
8.	Specifications	21
9.	Limited Product Warranty	22



Thank you for purchasing this power protection product. It has been designed and manufactured to provide many years of trouble free service.

**IMPORTANT SAFETY INSTRUCTIONS
SAVE THESE INSTRUCTIONS !**

Please read this manual before installing your Enterprise Plus Battery Packs, models EBP36XL, EBP72XL as it provides important information that should be followed during installation and maintenance of the Battery Packs and batteries allowing you to correctly set up your system for the maximum safety and performance. Included is information on customer support and factory service if it is required. If you experience a problem with the Battery Packs please refer to the Troubleshooting guide in this manual to correct the problem or collect enough information so that the Technical Support Department can rapidly assist you.



This symbol indicates "ATTENTION"



This symbol indicates "Risk of Electrical Shock"



This symbol indicates "Alternating Current Supply Phase"



This symbol indicates "Alternating Current Supply"



This symbol indicates "Direct Current Supply"



This symbol indicates "Equipment Grounding Conductor"



CAUTION! Connect the Battery Pack to a two pole, three wire grounding AC wall outlet. The receptacle must be connected to the appropriate branch protection (circuit breaker or fuse). Connection to any other type of receptacle may result in a shock hazard and violate local electrical codes. Do not use extension cords, adapter plugs, or surge strips.



CAUTION! To reduce the risk of electrical shock with the installation of these Battery Packs, with the UPS equipment and the connected equipment, the user must ensure that the combined sum of the AC leakage current does not exceed 3.5mA.



CAUTION! These Battery Packs are intended to be install in a temperature controlled environment that is free of conductive contaminants. Select a location which will provide good air circulation for the Battery Pack and UPS at all times.



WARNING: These Battery Packs contains potentially hazardous voltages. Do not attempt to disassemble the Battery Pack beyond the battery replacement procedure. These Battery Packs contains no user serviceable parts. Repairs and Battery replacement must be performed by **QUALIFIED SERVICE PERSONNEL ONLY.**



WARNING: Risk of Electrical Shock. Hazardous live parts inside these Battery Packs are energized from the battery even when the AC input is disconnected.



CAUTION! To de-energize the Battery Pack:

1. If the UPS is on press and release the On/Off/Test button.
2. Disconnect the UPS and the Battery Pack from the wall outlet.
3. Turn off the DC breaker on the rear panel of the Battery Pack.
4. Disconnect the battery cable from the rear panel of the UPS.
5. To de-energize the Battery Pack completely, disconnect the batteries.



WARNING: Qualified Service Personnel ONLY must perform the Installation and Servicing of these Battery Packs. MINUTEMAN accepts no liabilities and is not limited to: injury to the Service Personnel, or damages to; the Battery Pack, the UPS, or the connected equipment caused by the incorrect installation or servicing of the Battery Packs. These Battery Packs **MUST** be operated with their respective UPS models, see the table below:

Model #	EBP36XL	EBP72XL
UPS Model #	E750RM2U E1000RM2U E1500RM2U E1500RMT2U	ED2000RM2U ED3000RM2U ED3000RMT2U



NOTICE: This equipment has been tested and found to comply with the limits for a Class A computing device in accordance with the specifications in Subpart J of Part 15 of FCC Rules and the Class A limits for radio noise emissions from digital apparatus set out in the Radio Interference of the Canadian Department of Communications. These limits are designed to provide reasonable protection against such interference in a residential installation. This equipment generates and uses radio frequency and if not installed and used properly, that is, in strict accordance with the manufacturer's instructions, this equipment may cause interference to radio and television reception. If this equipment does cause interference to radio or television reception, which can be determined by turning the equipment off and on, the user is encouraged to try to correct the interference by one or more of the following measures:

- Re-orient the receiving antenna.
- Relocate the computer with respect to the receiver.
- Move the computer away from the receiver.
- Plug the computer into a different outlet so that the computer and receiver are on different branch circuits.
- Shielded communications interface cables must be used with this product.



WARNING: Changes or modifications to this unit not expressly approved by the party responsible for compliance could void the user's authority to operate the equipment.

Receiving Inspection

After removing your Battery Pack from its carton, it should be inspected for damage that may have occurred in shipping. Immediately notify the carrier and place of purchase if any damage is found. Warranty claims for damage caused by the carrier will not be honored. The packing materials that your Battery Pack was shipped in are carefully designed to minimize any shipping damage. In the unlikely case that the Battery Pack needs to be returned to the manufacturer, please use the original packing material. Since the manufacturer is not responsible for shipping damage incurred when the system is returned, the original packing material is inexpensive insurance.

PLEASE SAVE THE PACKING MATERIALS!

Life Support Policy

As a general policy, we do not recommend the use of any of our products in life support applications where failure or malfunction of the product can be reasonably expected to cause failure of the life support device or to significantly affect its safety or effectiveness. We do not recommend the use of any of our products in direct patient care. We will not knowingly sell our products for use in such applications unless it receives in writing assurances satisfactory to us that (a) the risks of injury or damage have been minimized, (b) the customer assumes all such risks, and (c) our liability is adequately protected under the circumstances.

Examples of devices considered to be life support devices are neonatal oxygen analyzers, nerve stimulators (whether used for anesthesia, pain relief, or other purposes), auto transfusion devices, blood pumps, defibrillators, arrhythmia detectors and alarms, pacemakers, hemodialysis systems, peritoneal dialysis systems, neonatal ventilator incubators, ventilators for both adults and infants, anesthesia ventilators, and infusion pumps as well as any other devices designated as “critical” by the United States FDA.

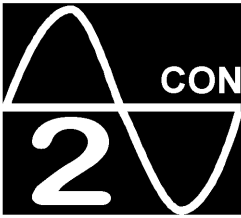

CONTROLS AND INDICATORS

INDICATOR PANEL

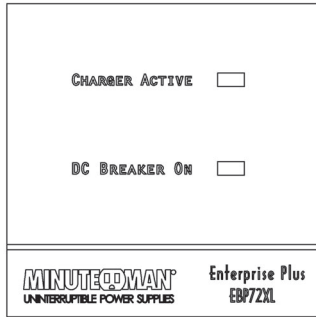

The Charger Active (green) LED illuminates in a steady state when the Charger is on. The Charger Active LED will extinguish when there is no acceptable AC present.

The DC Breaker On (green) LED illuminates in a steady state when the DC breaker is in the On position. The DC Breaker On LED will extinguish when the DC breaker is in the Off position.

REAR PANEL

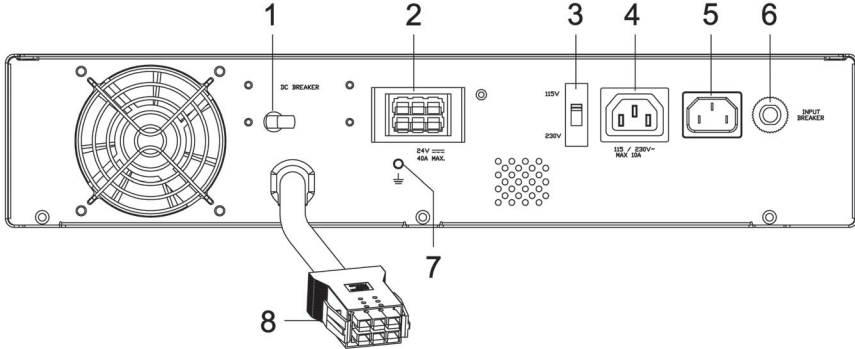

1. The DC Circuit Breaker connects and disconnects the DC bus voltage from the Battery Pack to the UPS. The DC Circuit Breaker will trip in the event of a DC over-current condition.
2. The External Battery connector is for Daisy Chaining additional Battery Packs.
3. The dipswitch is for setting the input voltage for the Battery Pack's internal charger.
4. The AC Outlet is for connecting the output cable to Daisy Chain additional Battery Packs.
5. The AC Inlet is for connecting the input power cord to operate the Charger.
6. The Input Breaker will trip in the event that the Internal Charger draws excessive current.
7. The External Ground Stud is for connecting an external ground wire.
8. The External Battery cable is for connecting the Battery Pack to the UPS or Daisy Chaining additional Battery Packs.

INSTALLATION

3

INSTALLATION PLACEMENT



These Battery Packs are intended to be install in a temperature controlled environment that is free of conductive contaminants. Select a location which will provide good air circulation for the Battery Pack at all times. Avoid locations near heating devices, water or excessive humidity, or where the Battery Pack is exposed to direct sunlight. Route power cords so they cannot be walked on or damaged.

ENVIRONMENTAL	
Operating Temperature (max)	0 to 40°C (+32 to +104°F)
Storage Temperature	-15 to +45°C (+5 to +113°F)
Operating/Storage Humidity	95% Non-Condensing
Operating Elevation	0 to 3,000m (0 to +10,000 ft)
Storage Elevation	0 to 15,000m (0 to +50,000 ft)
Audible Noise at 1 m (3 ft.)	<45 dBA

INSTALLATION

Be sure to read the installation placement and all the cautions before installing the Battery Pack. Place the Battery Pack in the final desired location and complete the rest of the installation procedure.



WARNING! These Battery Packs are extremely heavy. Any time the Battery Pack has to be handled be sure to use, enough personnel, strong supports and equipment to safely handle the Battery Pack.

RACKMOUNT CONFIGURATION

The Battery Pack comes with mounting brackets for the standard 19" (46.5cm) rack. The mounting brackets to fit a 23" (59.2cm) standard rack are also available. The screws for mounting the Battery Pack to the rack are not included (screw size varies with rack size).

1. Locate the mounting bracket screw holes on the side panels of the Battery Pack, at the front of the Battery Pack. **NOTE:** The mounting brackets can also be mounted in the middle of the Battery Pack.

2. Align the mounting bracket with the mounting bracket screw holes.

3. Attach the mounting bracket with the retaining screws.

4. Mount the Battery Pack into the rack and secure with the retaining screws.

WARNING: Use two or more people when installing the Battery Pack. Use **CAUTION**, the Battery Pack is extremely heavy. Do not move the rack after the units have been installed. The rack maybe unstable due to the weight distribution.

5. The Rackmount Configuration is complete. See Connecting the Battery Pack.

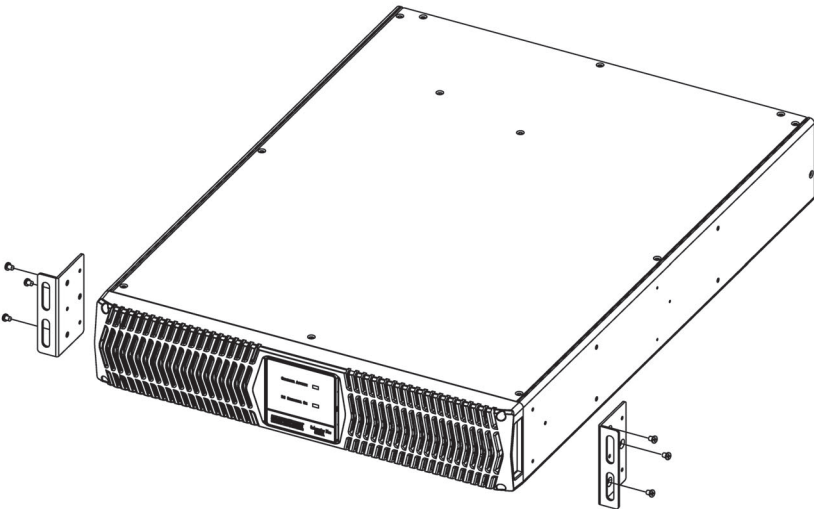

TOWER CONFIGURATION

The tower configuration allows the user to install the Battery Pack in the up-right position next to the UPS and the tower computer. The tower brackets are provided with the Battery Pack. **WARNING:** Use two or more people when installing the Battery Pack. Use **CAUTION**, the Battery Pack is extremely heavy.

1. Once the location of the Battery Pack has been determined, place the tower brackets in the desired location.

WARNING: The Battery Pack must be installed in the proper up-right position. If the Battery Pack is not installed in the proper up-right position the Batteries will be damaged. Once the Battery Pack is placed in the tower brackets, looking at the front panel of the Battery Pack the top cover of the Battery Pack **MUST** be on your left hand side.

2. Slide the Battery Pack into the tower brackets. Make sure that the Battery Pack is stable.
3. The LED face plate can be rotated to read in the up-right position. Remove the front panel from the Battery Pack. On the backside of the front panel, push the LED face plate outwards the face plate will pop out. Position the LED face plate so that it reads in the up-right position. Re-install the front panel on the Battery Pack.
4. The Tower Configuration is complete. See Connecting the Battery Pack.



WALLMOUNT CONFIGURATION

The wallmount configuration allows the user to mount the Battery Pack on the wall. There is a wallmount bracket kit available for the Battery Pack. The kit includes two wall mounting brackets, ten retaining screws, and the wallmount template. **WARNING:** Use two or more people when installing the Battery Pack. Use **CAUTION**, the Battery Pack is extremely heavy. The Battery Pack's side panels have mounting bracket screw holes for attaching the wall mounting brackets.

1. Once the location and position of the Battery Pack has been determined, lay the Battery Pack down flat.

WARNING: The Battery Pack must be installed in the proper up-right position. If the Battery Pack is not installed in the proper up-right position the Batteries will be damaged. Once the Battery Pack is placed on the wall, looking at the front panel of the Battery Pack the top cover of the Battery Pack **MUST** be on your left hand side.

WALLMOUNT CONFIGURATION (continued)

2. Align the mounting brackets with the mounting bracket screw holes and attach with the six retaining screws.
3. Use the template to mark the screw hole position on the wall. **CAUTION**, you should always wear protective gear for your hands and eyes when operating power tools.
4. Attach the four retaining screws to the wall and make sure that all of the retaining screws are screwed into structural material. Then clean the area of any loose material. Do not tighten the retaining screws all the way, leave approximately 3/8" of the retaining screws sticking out.
5. Position the Battery Pack, so that the mounting bracket keyed holes line up with the four retaining screws. Slide the Battery Pack down until its resting securely on the four retaining screws.
6. Tighten the four retaining screws to secure the Battery Pack to the wall.
7. The LED face plate can be rotated to read in the up-right position. Remove the front panel from the Battery Pack. On the backside of the front panel, push the LED face plate outwards the face plate will pop out. Position the LED face plate so that it reads in the up-right position. Re-install the front panel on the Battery Pack.
8. The Wallmount Configuration is complete. See Connecting the Battery Pack.

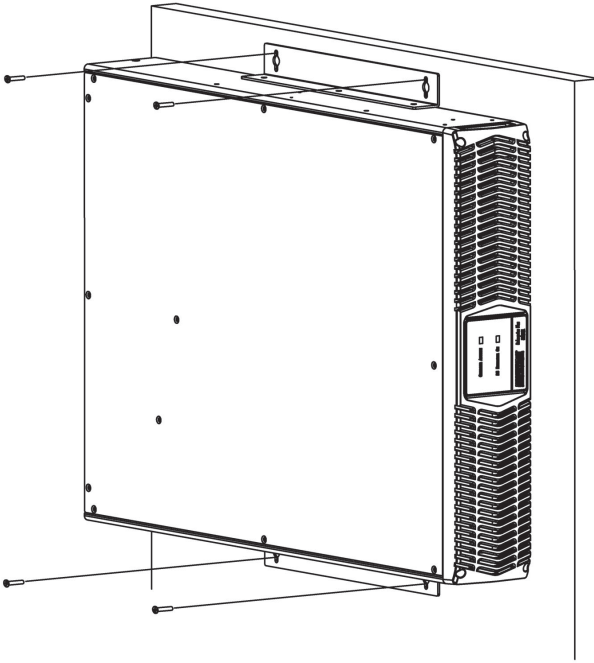

CONNECTING THE BATTERY PACK

(QUALIFIED SERVICE PERSONNEL ONLY)

NOTE: If you are using these Battery Packs with the Enterprise Plus series UPS, the UPS must be configured so that the UPS will report the correct estimated runtime in the SentryPlus software and to make the Battery capacity bar graph LEDs display properly. See the SentryPlus software User's Manual to configure the UPS.

1. Make sure that the DC circuit breaker on the rear panel of the Battery Pack is in the Off position.
2. Turn the UPS off and disconnect the UPS's input power cord from the AC wall outlet.
3. Remove the External Battery Connector cover from the UPS's rear panel.
4. Verify, before connecting the Battery Pack's external battery cable into the UPS's external battery connector, that they mate red to red and black to black. **NOTE:** The red connector is the battery positive (+) and the black connector is the battery negative (-). Connect the external battery cable from the Battery Pack to the external battery connector on the UPS. **NOTE:** If connecting more than one Battery Pack see Daisy Chaining.
5. See Connecting the Battery Pack to an AC Source.

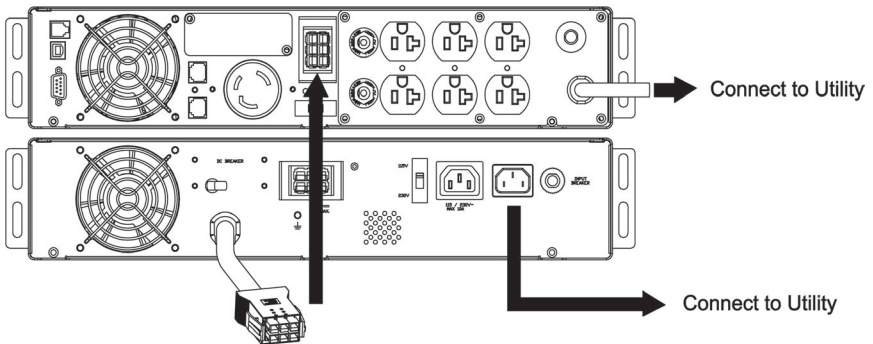

NOTE: The EBP72XL's External Battery Cable has a strain relief that must be attached (with the screw) to the rear panel of the UPS.

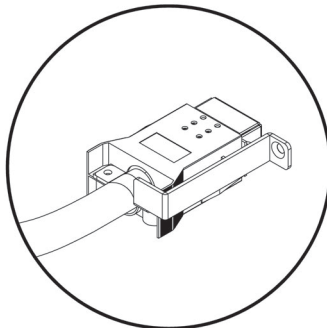

EBP72XL's External Battery Cable with strain relief.

CONNECTING THE BATTERY PACK TO AN AC SOURCE

These Battery Packs can operate with 115VAC or 230VAC input voltage. Before connecting the Battery Pack to an AC Source, verify that the Battery Pack's dipswitch is set for the proper input voltage.

1. Set the dipswitch on the rear panel of the Battery Pack to the appropriate input voltage.
2. Connect the input power cord for the Battery Pack into the AC Inlet on the Battery Pack.
3. Plug the other end of the input power cord for the Battery Pack into the AC wall outlet, use a two pole, three wire, grounded receptacle only. Do not use extension cords, adapter plugs, or surge strips.
4. Turn the DC circuit breaker to the On position. See the UPS User's Manual for the normal startup of the UPS. **NOTE:** If connecting more than one Battery Pack see Daisy Chaining.

CHARGING THE BATTERY

The Battery Packs will charge the internal batteries whenever the Battery Pack is connected to an AC source and there an acceptable AC voltage present. It is recommended that the Battery Packs be charged for a minimum of 4 hours before use. The Battery Pack maybe used immediately, however, the "On-Battery" runtime of the UPS may be less than normally expected. **NOTE:** If the Battery Pack is going to be out of service or stored for a prolonged period of time, the batteries must be recharged for at least 24 hours every ninety days.

DAISY CHAINING

(QUALIFIED SERVICE PERSONNEL ONLY)

"Daisy Chaining" means hooking one Battery Pack to another Battery Pack to another Battery Pack, this chain could go on indefinitely. Follow the steps below to Daisy Chain the Battery Packs.

1. Be sure to read the installation placement procedure, all of the cautions and the safety precautions before Daisy Chaining the Battery Pack(s).
2. Make sure that all, the Battery Pack's DC circuit breakers and UPS's power switch, are in Off position. **CAUTION:** If the Battery Pack's DC circuit breaker is in the On position, the battery voltage will be present at the open end of the Battery Pack's external battery cable and external battery connector. Unplug all the equipment that is plugged into the UPS's output receptacles. Disconnect the power cords, that are on the Battery Packs and the UPS, from the AC wall outlet.
3. Remove the External Battery Connector cover from the UPS's rear panel and the additional Battery Packs.
4. Verify, before plugging the external battery cable into the UPS's external battery connector or the Battery Pack's external connector that they mate red to red and black to black.
5. Connect the external battery cable from the first Battery Pack to the external battery connector on the UPS.
6. Connect the external battery cable from the second Battery Pack to the external battery connector on the first Battery Pack.

7. Before connecting the Battery Pack to an AC Source, verify that the Battery Pack is set for the proper input voltage. Set the dipswitch on the rear panel of the Battery Pack to the appropriate input voltage. Connect the input power cord with the NEMA 5-15P Plug into the AC Inlet on the first Battery Pack.
8. Connect the Daisy Chain power cord from the AC Outlet of the of the first Battery Pack to the AC Inlet of the second Battery Pack.
9. Connect the input power cord (with the NEMA 5-15P Plug) from the first Battery Pack into the AC wall outlet.
10. Turn ALL of the DC circuit breakers on the rear panel of the Battery Packs to the On position.
11. The Battery Packs are ready for normal operation, see the UPS User's Manual for the normal startup of the UPS.

NOTE: The maximum number that can be Daisy Chained for the AC source is five Battery Packs. There is no maximum number for Daisy Chaining the DC bus voltage for the Battery Packs.

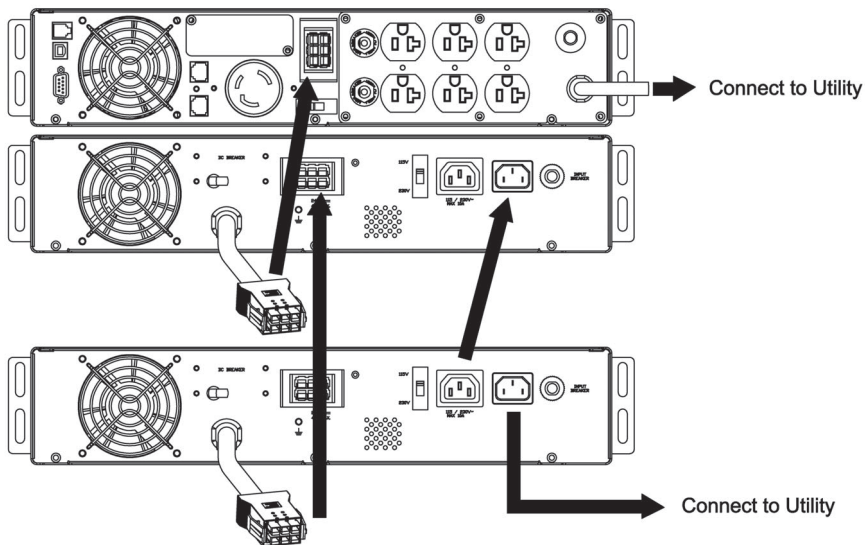

NOTE: The EBP72XL's External Battery Cable has a strain relief that must be attached (with the screw) to the rear panel of the UPS.

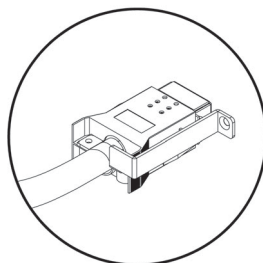

EBP72XL's External Battery Cable with strain relief.

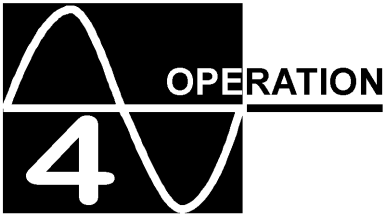

SYSTEM OVERVIEW

These Battery Packs will extend the runtime capabilities of the UPS. These Battery Packs have internal chargers to properly maintain the internal batteries. The charger will operate with 115VAC or 230VAC depending on the dipswitch setting. The Battery Pack will charge the batteries with the DC circuit breaker in the On or Off position as long as the Battery Pack is plugged into the AC wall outlet and there is an acceptable AC voltage present (90 - 130VAC/180 - 260VAC). When the commercial power is lost the charger will turn Off and the Battery Pack will extend the runtime of the UPS. When the commercial power returns the Battery Pack's internal charger will automatically start recharging the batteries. During normal AC operation, the UPS and Battery Pack will quietly and confidently protect your system from power anomalies.

TURNING THE BATTERY PACK ON/OFF

Turning the DC circuit breaker to the On position will connect the DC bus voltage from the Battery Pack to the UPS. Turning the DC circuit breaker to the Off position will disconnect the DC bus voltage from the Battery Pack to the UPS. The DC circuit breaker does NOT turn on or turn off the internal charger. Plug the input power cord into the AC wall outlet to turn on the internal charger. Unplug the input power cord to turn off the internal charger. The Battery Pack's internal charger will continue to charge the batteries whenever it is plugged into an AC wall outlet and there is acceptable AC voltage present (90 - 130VAC/180 - 260VAC).

DIPSWITCH SETTINGS

The dipswitch setting may be changed by the user to set the desired input voltage for the Battery Pack's internal charger. The dipswitch must be set with the DC circuit breaker in the Off position and with the input power cord disconnected from the AC wall outlet. Set the dipswitch to 115VAC or 230VAC. Plug the input power cord into the AC wall outlet and turn the DC circuit breaker to the On position.

INDICATORS

The Charger Active (green) LED illuminates in a steady state when the Charger is on. The Charger Active LED will extinguish when there is no AC present.

The DC Breaker On (green) LED illuminates in a steady state when the DC circuit breaker is in the On position. The DC Breaker On LED will extinguish when the DC circuit breaker is in the Off position.



TROUBLESHOOTING

5

Symptom	Possible Cause	What To Do
The Charger Active LED is not on.	<ol style="list-style-type: none"> 1. The input power cord is not plugged into the AC wall outlet. 2. No commercial power available. 3. No AC voltage at the AC wall outlet. 4. Internal charger fault. 	<ol style="list-style-type: none"> 1. Plug the input power cord into the AC wall outlet. 2. Once commercial power is available recheck the LED. 3. Check the circuit breaker at the service panel to see if it is tripped. 4. Call for Service.
The DC Breaker On LED is not on.	<ol style="list-style-type: none"> 1. The DC circuit breaker is in the Off position. 2. The DC circuit breaker is tripped. 3. The internal battery wires are disconnected. 4. Internal fault. 	<ol style="list-style-type: none"> 1. Turn the DC circuit breaker to the On position. 2. Reset the DC circuit breaker. 3. Reconnect the internal battery wires. 4. Call for Service.
The charger is not providing the correct charge voltage.	<ol style="list-style-type: none"> 1. The input power cord is not plugged into the AC wall outlet. 2. The dipswitch is not set to the correct input voltage. 3. The charger has an internal fault. 	<ol style="list-style-type: none"> 1. Plug the input power cord into the AC wall outlet. 2. Set the dipswitch to the correct setting. 3. Call for Service.

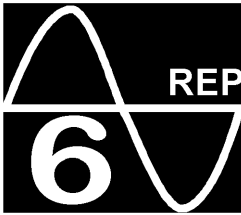

REPLACING THE BATTERY

REPLACING THE BATTERY

(QUALIFIED SERVICE PERSONNEL ONLY)

These Battery Packs have an easy to replace hot-swappable batteries. Please read all of the WARNINGS and CAUTIONS before attempting to service the batteries.

NOTE: If there is a power interruption while replacing the hot-swappable batteries, the the UPS on, the load will not be backed up.

WARNING! This Battery Pack contains potentially hazardous voltages. Do not attempt to disassemble the Battery Pack beyond the battery replacement procedure. These Battery Packs contain no user serviceable parts. Repairs and Battery replacement must be performed by **QUALIFIED SERVICE PERSONNEL ONLY**.



CAUTION: Do not open or mutilate batteries. Released electrolyte is harmful to the skin and eyes and may be toxic.

CAUTION: Do not dispose of batteries in a fire. The batteries may explode. The batteries in this Battery Pack are recyclable. Dispose of the batteries properly. The batteries contain lead and pose a hazard to the environment and human health if not disposed of properly. Refer to local codes for proper disposal requirements or return the battery to the supplier.



CAUTION: Although battery system voltages are only 36VDC and 72VDC the battery system can still present a risk of electrical shock. These batteries produce sufficient current to burn wire or tools very rapidly, producing molten metal. Observe these precautions when replacing the batteries:



1. Remove watches, rings, or other metal objects.
2. Use hand tools with insulated handles.
3. Wear protective eye gear (goggles), rubber gloves and boots.
4. Do not lay tools or other metal parts on top of batteries.
5. Disconnect the charging source prior to connecting or disconnecting the battery terminals.
6. Determine if the battery is inadvertently grounded. If the battery is, remove the source of the grounding. Contact with any part of a grounded battery can result in an electrical shock. The likelihood of such shock will be reduced, if such grounds are removed during installation and maintenance.

CAUTION: Replace the batteries with the same number and type as originally installed in the Battery Pack. These batteries have pressure operated vents. These Battery Packs contain sealed non-spillable maintenance free lead acid batteries.

Model #	EBP36XL	EBP72XL
Battery Qty/Rating	6-12V7.2Ah	6-12V8.5Ah
CSB Part #	GP 1272 F2	HR 1234W F2
Panasonic Part #	LC-R127.2	LC-R129
Yuasa Part #	NP-7.2-12	REW45-12

BATTERY REPLACEMENT PROCEDURE

(QUALIFIED SERVICE PERSONNEL ONLY)

PLEASE READ THE CAUTIONS AND WARNINGS BEFORE ATTEMPTING TO REPLACE THE BATTERIES

Hot-swappable batteries mean that the batteries can be replaced without powering down the whole UPS system.

NOTE: If there is a power interruption while replacing the hot-swappable batteries, with the UPS on, the load will not be backed up. To hot-swap the Battery Pack's batteries start with step number 6.

1. Turn off the equipment that is plugged into the output receptacles of the UPS.
2. Press and release the On/Off/Test button on the front panel to turn the UPS off.
3. Unplug the UPS's AC power cord from the AC wall outlet.
4. Unplug the equipment from the output receptacles of the UPS.
5. Unplug the computer interface cable from the rear panel of the UPS.
6. Turn off all of the DC circuit breakers on the rear panel of all of the Battery Packs.
7. Unplug all of the Battery Pack's AC power cords from the AC wall outlet.
8. Disconnect all of the external battery cables.
9. Remove the front panel retaining screws. (FIG. 2)
10. Lay the front panel on top of the Battery Pack.
11. Remove the retaining screws for the battery retaining brackets. (FIG. 3)
12. Remove the battery retaining brackets. (FIG. 3)
13. Disconnect the battery connectors (red and black) one from each battery module. (FIG. 4)
14. Grasp one of the battery pull tabs and gently pull the battery module out of the Battery Pack and set on the floor. (FIG. 4)

15. Grasp the other battery pull tab and gently pull the battery module out of the Battery Pack and set on the floor. (FIG. 4)

NOTE: Use Caution, the battery modules are heavy.

16. Disconnect the battery positive (red) wires.
17. Disconnect the battery negative (black) wires.
18. Disconnect the battery jumper wires.
19. Remove the old batteries from the battery tray.
20. Install the new batteries into the battery tray in the same position as the original batteries.
21. Verify proper polarity. Re-install the battery jumper wires on the new batteries.
22. Verify proper polarity. Reconnect the battery negative (black) wires.
23. Verify proper polarity. Reconnect the battery positive (red) wires.
24. Slide the battery module into the Battery Pack.
25. Verify proper polarity. Reconnect the battery connectors (red and black).

NOTE: Some sparking might occur, this is normal.

26. Re-install the battery retaining bracket.
27. Re-install the retaining screws for the battery retaining bracket.
28. Re-install the front panel on the Battery Pack.
29. Re-install the front panel retaining screws.
30. Reconnect all of the external battery cables.
31. Plug in all of the Battery Pack's AC power cords into the AC wall outlet.
32. Turn on all of the DC circuit breakers on the rear panel of all of the Battery Packs.
33. Properly dispose of the old batteries at an appropriate recycling facility or return them to the supplier in the packing material for the new batteries.
34. The Battery Pack is ready for normal operation.

NOTE: If the UPS has a Weak/Bad Battery Alarm after replacing the batteries, the user must initiate a self test to clear the Weak/Bad Battery Alarm. To initiate a self test see section 4 "**SELF TEST**" in the UPS's User's Manual.

FIG. 1

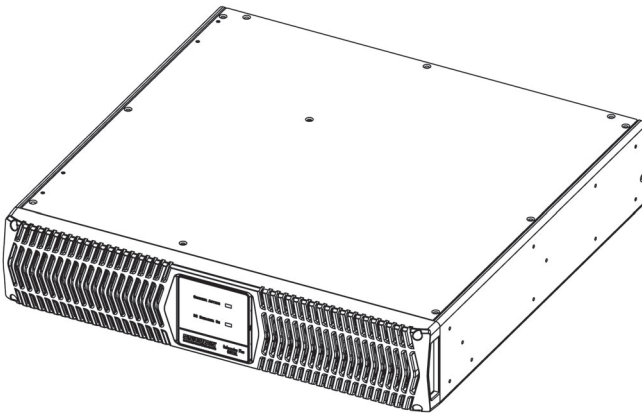

FIG. 2

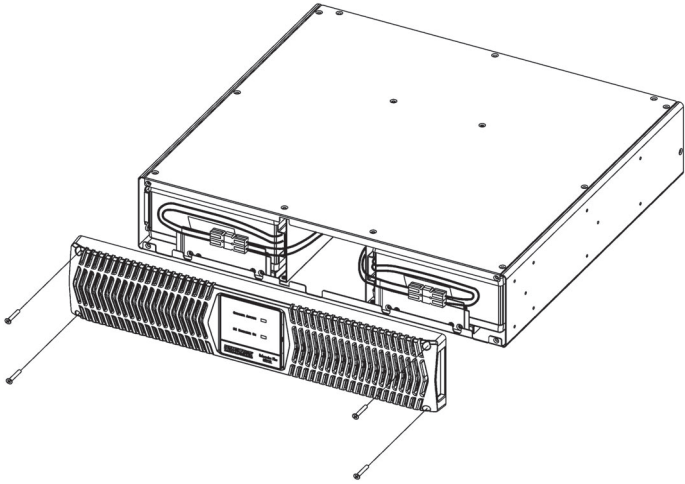

FIG. 3

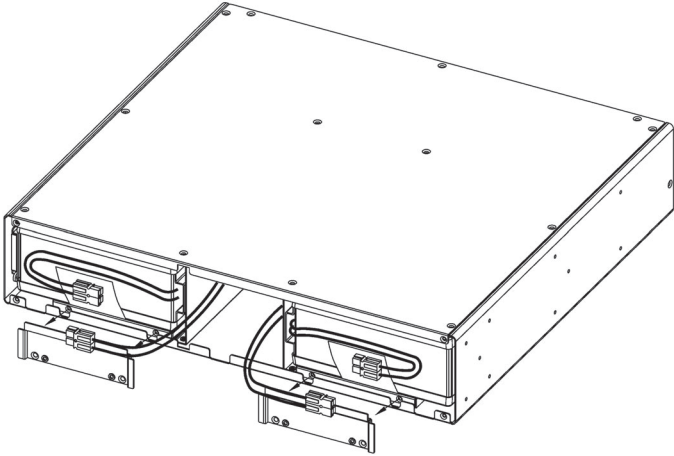
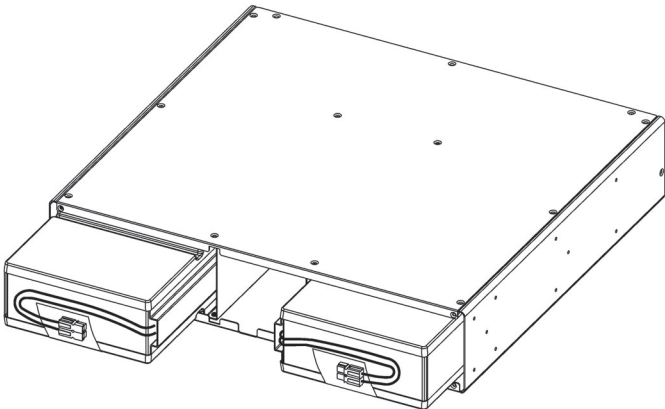
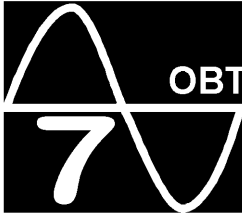

FIG. 4





OBTAINING SERVICE

English

IF THE UPS REQUIRES SERVICE

1. Use the **TROUBLESHOOTING** section to eliminate obvious causes.
2. Verify there are no circuit breakers tripped. A tripped circuit breaker is the most common problem.
3. Call your dealer for assistance. If you cannot reach your dealer, or if they cannot resolve the problem call or fax MINUTEMAN Technical Support at the following numbers; Voice phone (972) 446-7363, FAX line (972) 446-9011 or visit our Web site at www.minutemanups.com the "Discussion Board". Please have the following information available BEFORE calling the Technical Support Department.
 - A. Your name and address.
 - B. Where and when the unit was purchased.
 - C. All of the model information about your Battery Pack and UPS.
 - D. Any information on the failure, including LEDs that may be illuminated.
 - E. A description of the protected equipment, including model numbers if possible.
 - F. A technician will ask you for the above information and, if possible, help solve your problem over the phone. In the event that the unit requires factory service, the technician will issue you a Return Material Authorization Number (RMA #).
 - G. If the Battery Pack is under warranty, the repairs will be done at no charge. If not, there will be a charge for repair.
4. Pack the Battery Pack in its original packaging. If the original packaging is no longer available, ask the Technical Support Technician about obtaining a new set. It is important to pack the Battery Pack properly in order to avoid damage in transit. Never use Styrofoam beads for a packing material.
 - A. Include a letter with your name, address, day time phone number, RMA number, a copy of your original sales receipt, and a brief description of the problem.
5. Mark the RMA # on the outside of all packages. The factory cannot accept any package without the RMA # marked on the outside.
6. Return the Battery Pack by insured, prepaid carrier to:

Para Systems Inc.
MINUTEMAN UPS
1455 LeMay Drive
Carrollton, TX 75007
ATTN: RMA # _____

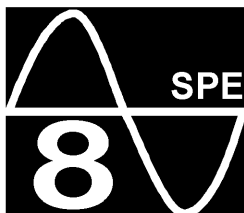

SPECIFICATIONS

SYSTEM SPECIFICATIONS		
Model Number	EBP36XL	EBP72XL
Format	Rack/Tower Convertible / Wallmount	
CHARGER INPUT		
Number of Phases	Single (1Ø 2W +G)	
Nominal Voltage	115/230VAC (dipswitch selectable)	
Voltage Range	115VAC: 90 - 130VAC (230VAC: 180 - 260VAC)	
AC Current	2.6 Amps	
Frequency Limits	50 or 60 Hz, +/-6Hz, autosensing	
Input Protection	Resettable Circuit Breaker	
CHARGER OUTPUT		
DC Voltage	41.4VDC +/-5%	82.8VDC +/-5%
DC Current	2.1 Amps	
Output Protection	Resettable Circuit Breaker	
BATTERY SYSTEM		
Battery Type	Sealed, Non-Spillable, Maintenance Free, Value Regulated, Lead Acid	
Typical Recharge Time	8-hours from total discharge	
Typical Battery Life	3-5 years, depending on discharge cycles and ambient temp	
System Voltage	36VDC	72VDC
System Current	40 Amps	
Battery Qty/Rating	6 - 12V7.2Ah	6 - 12V8.5Ah
PHYSICAL		
Size - Net L X W X H	17.0 x 17.3 x 3.5" 432 x 440 x 89 mm	
Weight - Net	55.0 lbs 25.0 Kgs	
Size - Shipping L X W X H	23.6 x 20.0 x 9.0" 600 x 508 x 230 mm	
Weight - Shipping	64.0 lbs 29.0 Kgs	
REGULATORY COMPLIANCE		
Safety and Approvals	UL1778, cUL (CSA 22.2 no. 107.1)	
EMC Verification	FCC Class A, CE certified	

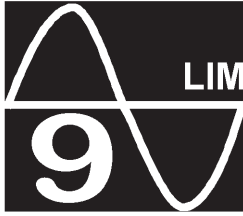

LIMITED PRODUCT WARRANTY

English

Para Systems Inc. (Para Systems) warrants this equipment, when properly applied and operated within specified conditions, against faulty materials or workmanship for a period of three years from the date of purchase. For equipment sites within the United States and Canada, this warranty covers repair or replacement of defective equipment at the discretion of Para Systems. Repair will be from the nearest authorized service center. Replacement parts and warranty labor will be borne by Para Systems. For equipment located outside of the United States and Canada, Para Systems only covers faulty parts. Para Systems products repaired or replaced pursuant to this warranty shall be warranted for the unexpired portion of the warranty applying to the original product. This warranty applies only to the original purchaser who must have properly registered the product within 10 days of purchase.

The warranty shall be void if (a) the equipment is damaged by the customer, is improperly used, is subjected to an adverse operating environment, or is operated outside the limits of its electrical specifications; (b) the equipment is repaired or modified by anyone other than Para Systems or Para Systems approved personnel; or (c) has been used in a manner contrary to the product's User's Manual or other written instructions.

Any technical advice furnished before or after delivery in regard to use or application of Para Systems's equipment is furnished without charge and on the basis that it represents Para Systems's best judgment under the circumstances, but it is used at the recipient's sole risk.

EXCEPT AS PROVIDED HEREIN, PARA SYSTEMS MAKES NO WARRANTIES, EXPRESSED OR IMPLIED, INCLUDING WARRANTIES OF MERCHANTABILITY AND FITNESS FOR A PARTICULAR PURPOSE. Some states do not permit limitation of implied warranties; therefore, the aforesaid limitation(s) may not apply to the purchaser.

LIMITED PRODUCT WARRANTY

(Continued)

EXCEPT AS PROVIDED ABOVE, IN NO EVENT WILL PARA SYSTEMS BE LIABLE FOR DIRECT, INDIRECT, SPECIAL, INCIDENTAL, OR CONSEQUENTIAL DAMAGES ARISING OUT OF THE USE OF THIS PRODUCT, EVEN IF ADVISED OF THE POSSIBILITY OF SUCH DAMAGE. Specifically, Para Systems is not liable for any costs, such as lost profits or revenue, loss of equipment, loss of use of equipment, loss of software, loss of data, cost of substitutes, claims by third parties, or otherwise. The sole and exclusive remedy for breach of any warranty, expressed or implied, concerning Para Systems's products and the only obligation of Para Systems hereunder, shall be the repair or replacement of defective equipment, components, or parts; or, at Para Systems's option, refund of the purchase price or substitution with an equivalent replacement product. This warranty gives you specific legal rights and you may also have other rights which vary from state to state.

Longer term warranties are available at an additional cost. Contact Para Systems (1-972-446-7363) for details.

Notes:

English

 <p>RoHS Compliant</p>	<p>This product complies with the Restriction of certain Hazardous Substances (RoHS) Directive as conceived by the European Union committee in 2002. Products that meet the RoHS standard have been redesigned to remove the lead, mercury, cadmium, hexavalent chromium where applicable. As part of our efforts to maintain a healthy environment, Para Systems has proactively adopted these standards for our Minuteman® brand products.</p>
--	--

Para Systems, Inc.
1455 Lemay Dr.
Carrollton, TX 75007
Phone: 1-972-446-7363
Fax: 1-972-446-9011
Internet: minutemanups.com
UPS Sizing: sizemyups.com

P/N 34000272